

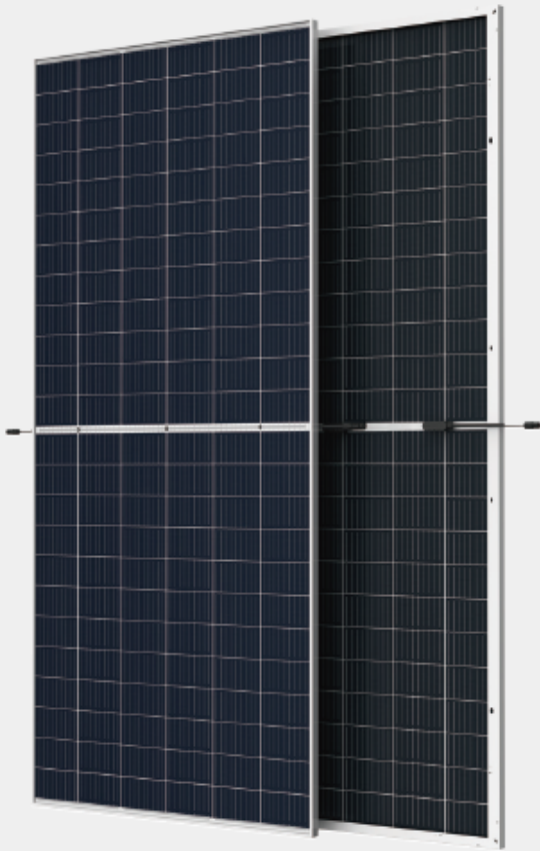

Einnova Solarline

invented for solar

Bifacial PERC Half Cut Mono Crystalline Solar Module ESM-395/400/405/410/415S-transparent backsheet





KEY FEATURES

- 

Excellent module efficiency up to: 21.30%, bifacial, higher power yield
- 

IP68 junction box for long-term weather endurance
- 

Heavy snow loading up to 5400 Pa, wind loading up to 2400 Pa
- 

PID: selected material and stringent quality system ensure PID free
- 

Applicable to harsh environment of deserts, farmlands and seashores
- 

Much lower risk of Hot Spot

CERTIFICATE



30 Years Power Output Warranty ■

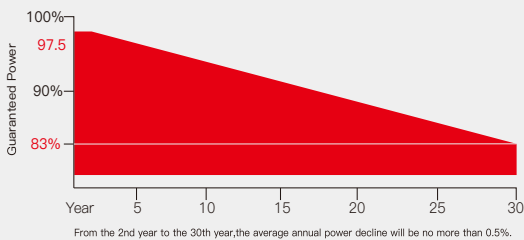

WARRANTY

- 

Linear power output warranty
-12 years minimum 92% power output
-30 years minimum 83% power output
- 

Product warranty on materials and workmanship
According to the applicable Einnova Solarline Limited Warranty Statement

Einnova Solarline

invented for solar

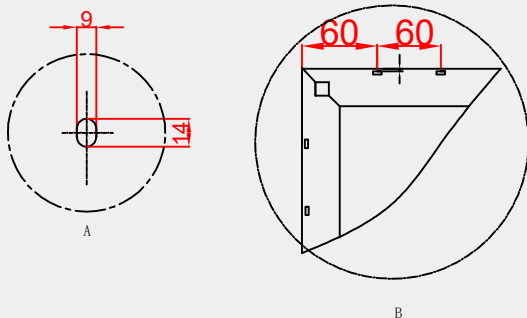
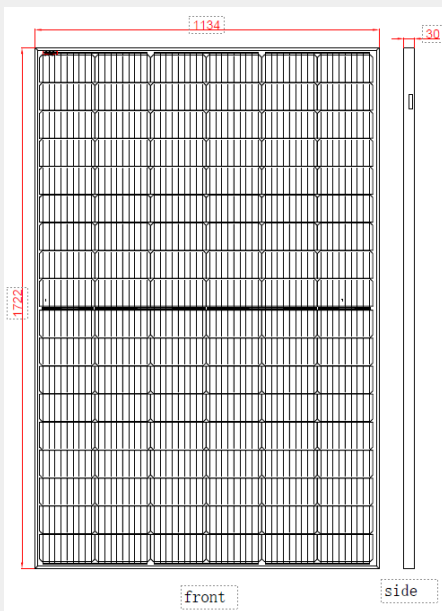
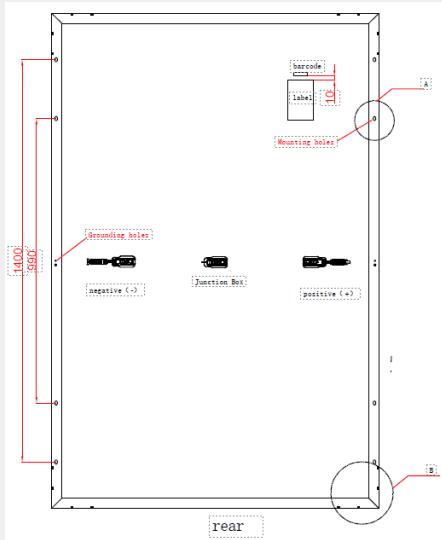

IV CURVE

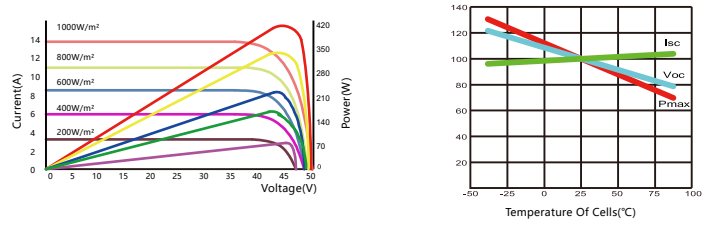

ELECTRICAL SPECIFICATION	Unit	ESM-395S	ESM-400S	ESM-405S	ESM-410S	ESM-415S
Maximum Power (Pmax)	W	395	400	405	410	415
Module Efficiency (%)	%	20.2	20.5	20.7	20.90	21.25
Open Circuit Voltage (Voc)	V	36.75	36.95	37.15	37.35	37.55
Short Circuit Current (Isc)	A	13.72	13.78	13.84	13.9	13.96
Maximum Power Voltage (Vmp)	V	30.87	31.07	31.27	31.47	31.49
Maximum Power Current (Imp)	A	12.80	12.87	12.95	13.03	13.17
Maximum System Voltage	V	ICE 1500VDC				
STC:Irradiance:1000W/m ² ,Module Temperature:25°C,Air Mass:1.5						

ELECTRICAL DATA@NOCT	ESM-395S	ESM-400S	ESM-405S	ESM-410S	ESM-415S
Pmax [W]	316	320	324	328	332
Vmp[V]	30.58	30.78	30.98	31.18	31.38
Imp[A]	10.33	10.40	10.46	10.52	10.58
Voc[V]	36.41	36.61	36.81	37.01	37.21
Isc[A]	11.08	11.13	11.18	11.23	11.28
NOCT:Irradiance:800W/m ² , Ambient Temperature:20°C,Air Mas:1.5,Wind Speed:1m/s					

MECHANICAL SPECIFICATIONS	
Solar Cell Type	Mono-crystalline 182x91mm cells
Number of Cells	108pcs
Module Size	1722x1134x30mm
Weight	19.0kg
Glass	3.2mm tempered glass
Back Sheet	Transparent
Frame	Anodized aluminum alloy,silver
Junction Box	IP68, three diodes
Quantity of Diodes	3pcs
Cable	4.0mm ² 1000mm
Connector	MC4 Compatible
Wind/Snow Load	2400pa/5400pa

TEMPERATURE CHARACTERISTIC	
NMOT (Nominal Module Operating Temperature)	45°C (±2°C)
Temperature Coefficient of P _{MAX}	- 0.36%/°C
Temperature Coefficient of U _{OC}	- 0.26%/°C
Temperature Coefficient of I _{SC}	0.04%/°C

PACKAGING CONFIGURATION	
Modules per box:	36pcs
Number per 20GP:	336pcs
Modules per 40' HQ:	936pcs

MAXIMUM RATINGS	
Operational Temperature	-40 to +85°C
Maximum System Voltage	1500V DC(IEC)
Max Series Fuse Rating	25 A
Protection Class	Class II
Snow Loading	5400 Pa
Wind Loading	2400 Pa
Hailstone Test	25mm Hailstone at the speed of 23m/s

* design load with safety factor 1.5
(DO NOT connect Fuse in Combiner Box with two or more strings in parallel connection)